

Methodological Innovations in Connection with the Zoological and Ecological Examinations of the Littoral Region

By

GY. KERTÉSZ, S. ANDRIKOVICS and P. SZERBIN*

In consequence of their shallowness, the lakes of Hungary are biological objects of European limnology followed with marked attention. Also their hydrobiological specificity is, in the first place, a consequence of their shallowness. According to classical limnology, in these waters the littoral region has an outstanding significance, i.e. macrovegetation and the productive layer taken in the proper sense of the word mean in these lakes the whole of the lake. The merging into one another of the biological processes, as well as the extensive and simultaneous presence of emergent and submerged macrovegetation greatly impede the follow-up of the processes of zoology, of nutrition biology. All these generally known facts are in part expressed in the data of the literature dealing with zoological research into the areas covered with macrovegetation of the Central European waters.

Literature that could fill a library accumulated up to now on the Rotatoria and Crustacea fauna of the open-water areas of the Polish lake region, of the Balaton, as well as of the Velence and Fertő lakes. On the other hand, compared with these publications, the number of the works dealing with the animal communities of the areas covered with macrovegetation is remarkably low.

Among the papers published on the subject the study of KORINKOVA (1971) on lakes of Northern Slovakia is prominent. Besides the results also the adopted method is worthy of particular attention in this study. The said method consists in a frame of 1×1 m, which is covered with a net, and of which the lower part is covered with a net, and of which the lower part is shut by means of control from above.

The exact quantitative collection of the planktonic organisms, rotifers and crayfish among plant stands was performed first by SMYLY (1952). His results are significant, the methods require an exceeding amount of work and a maximal knowledge of the given terrain. Actually, a generally accepted method of modelling these stands is not yet known even today.

* *Dr. György Kertész, Dr. Sándor Andrikovics and Pavel Szerbin, ELTE Állatrendszertani és Ökológiai Tanszék (Zoosystematical and Ecological Institute of the Eötvös Loránd University), Budapest, Puskinu. 3, H – 1088.*

In the present study the authors report on the zoological collecting methods adopted by them as researchers of hydrozoology of the Zoosystematical and Ecological Institute of the Eötvös Loránd University as a routine in the course of the hydrological survey of the Velence and Fertő lakes.

The history of developing the collecting methods

The collections conducted in the lakes Fertő and Velence showed a conspicuous and often almost unexplainable poverty in fauna. The results can be explained by special ecological effects (formation of H_2S , deficiency in O_2). Besides all these, one should by all means take into consideration the special problems connected with the collection technique applied in this terrain.

With the traditional nets of circular shape or of the dredging type representative sampling from reedy, rughy or sedgy stands is a task next to unsolvable. It is by means of these instruments with which the authors took samples from verges of reed fields or from spots of pondweed. However, for collecting animal communities living in several metres high reeds, standing in water the traditional net frames cannot be used. Upon the suggestion of the Austrian hydrozoologist IMHOF, the authors constructed a net frame of drop form (Figure 1), the application of which they found remarkably expedient. The instrument proved best was a frame of 21 cm in length and 9 cm width drawn into a tip. The handling of the net does not demand much practice. The basic condition of the success of the collection is an approach taking care of the site. Besides this, the drawing of the "drop net" from the direction of the mud, upwards from below is important. Otherwise, namely, one has to reckon with the escape of the nimble organisms.

About collecting methods of quantitative character

The emergent macrovegetation areas of the extensive Hungarian shallow lakes are impopulated by animal communities often small in numbers of species, yet at the same time of great numbers of individuals. The authors' own examinations performed up to now prove that in sampling from pondweed fields and reed stands the introduction of a collecting method, relatively simple and also suitable for taking series of samples would be especially important. For this purpose they suggest a series of tubes drawn into one another telescopically (Figure 1b).

With a view to the demand of also collecting the more nimble organisms, here too a cautious approach to the site of collection is highly important. Having cut off the reed stalks above the water, a waiting period of 1/2 to 1 hour is advisable. After this time has passed, the next phase of the work of collection is to apply the appropriate tubes and cutting off the lower parts of the reed stalks. The last phase of sampling is closing by means of the rectangularly bent special net. With this method the authors suggest three parallel samplings from each site, and in this way — according to their observations — the results can easily be evaluated also statistically.

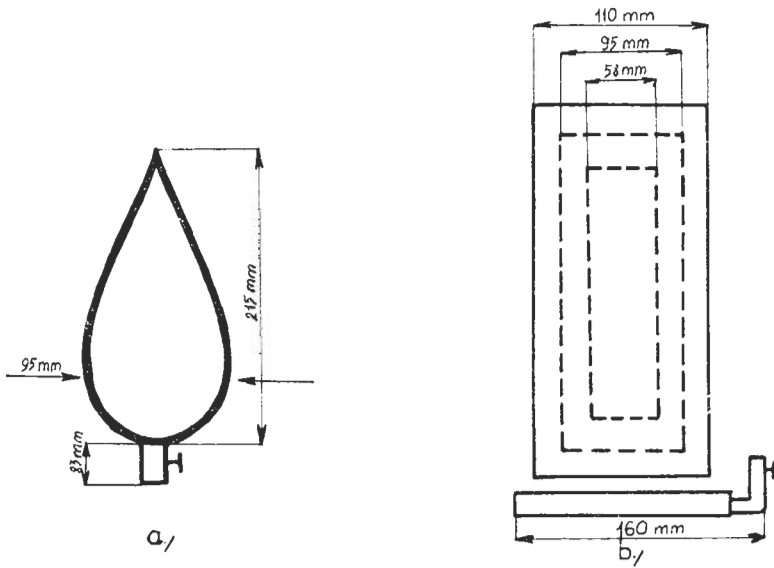

Fig. 1. a) The drop-formed collecting net; b) Tube series and closing net suitable for quantitative collection

Method of collecting mesoplankton occurring in the open areas of water of the not easily approachable habitats

In reedy or rushy habitats and for zoological collection from under the ice in wintertime the Triplex brand of a hand-driven pump proved good (Figure 2).

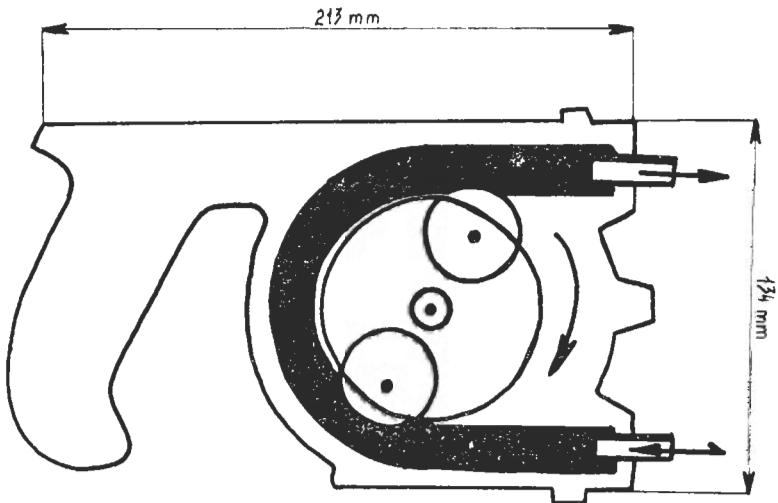

Fig. 2. Sketch of the Triplex pump

In the course of examining the mode of operation, the authors found that at a greater speed of turning the performance of the pump decreased. A probable cause of this is the appearance of the resonance phenomenon. In connection with collecting Cladocera and Copepoda they also conducted experiments in aquaria. The appliance lifted out 100% of the Cladocera and 80% of the Copepoda.

Besides zoological examinations, the simple appliance is by all means suited for performing chemical sampling. According to the authors' laboratory examinations, the samples obtained with this method do not change their original condition, so they can strongly advise the use of this appliance in examinations of micro-stratification and of the special conditions of water chemistry prevailing in the interior of dense plant stands.

REFERENCES

1. KORIŇKOVÁ, J. (1971): Sampling and distribution of animals in submerged vegetation. — Vestník Českoslov. Společn. Zoo., 35: 209 — 221.
2. SMYLY, W. J. P. (1952): The Entomostraca of the weeds of a moorland pond. — J. Anim. Ecol., 21: 1 — 11.
3. KGSZT Egységes vízvizsgáló módszerek. III. Biológiai módszerek (1976): Budapest (II. kiadás): 1 — 250. (COMECON Uniform Water Examination Methods III. Biological Methods.)